



Central Plate
Electronics Co.,Ltd.

F1A THRU F1M

GLASS PASSIVATED FAST RECOVERY RECTIFIER
Reverse Voltage: 50 to 1000 Volts Forward Current:1.0Ampere

FEATURES

- Glass passivated junction
- For Surface Mount Applications, Easy to pick and place
- Plastic package has Underwriters Laboratory Flammability Classification 94V-0
- High temperature soldering guaranteed:260°C/10 seconds at terminals,
- Component in accordance to RoHS 2002/95/EC and WEEE 2002/96/EC

MECHANICAL DATA

- Case: SOD-123FL molded plastic
- Terminals: Solder plated, solderable per MIL-STD-750, Method 2026
- Polarity: Color band denotes cathode end
- Mounting Position: Any
- Weight: 0.01 gram

SOD-123FL

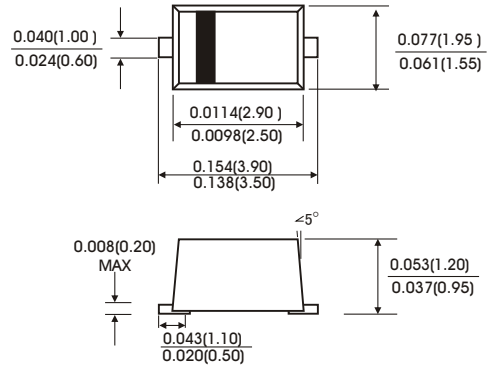

Dimensions in inches and (millimeters)

MAXIMUM RATINGS AND ELECTRICAL CHARACTERISTICS

(Rating at 25°C ambient temperature unless otherwise specified.Single phase ,half wave ,60Hz,resistive or inductive load. For capacitive load,derate current by 20%.)

	Symbols	F1A	F1B	F1D	F1G	F1J	F1K	F1M	Units
Maximum Recurrent Peak Reverse Voltage	V _{RRM}	50	100	200	400	600	800	1000	Volts
Maximum RMS Voltage	V _{RMS}	35	70	140	280	420	560	700	Volts
Maximum DC Blocking Voltage	V _{DC}	50	100	200	400	600	800	1000	Volts
Maximum Average Forward Rectified Current at T _L =100°C	I(AV)	1.0							Amps
Peak Forward Surge Current 8.3ms single half sine-wave superimposed on rated load (JEDEC method)	I _{FSM}	25.0							Amps
Maximum Instantaneous Forward Voltage at 1.0 A	V _F	1.3							Volts
Maximum DC Reverse Current at rated DC blocking voltage	T _A =25°C	5.0							μA
	T _A =125°C	50							
Maximum reverse recovery time(Note1)	t _{rr}	150			250	500	ns		
Typical junction capacitance(Note2)	C _J	15.0							pF
Operating junction and storage temperature range	T _J T _{STG}	-55 to +150							°C

Note: 1.Test conditions: I_F=0.5A,I_R=1.0A,I_{RR}=0.25A.

2.Measured at 1MHz and applied reverse voltage of 4.0 Volts D.C.



FIG.1-TYPICAL FORWARD CURRENT DERATING CURVE

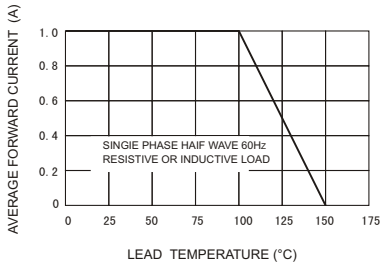

FIG.2-MAXIMUM NON-REPETITIVE FORWARD SURGE CURRENT

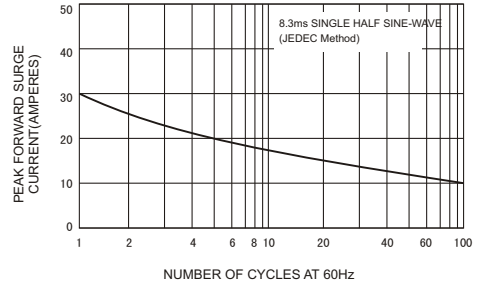

FIG.3-TYPICAL INSTANTANEOUS FORWARD CHARACTERISTICS

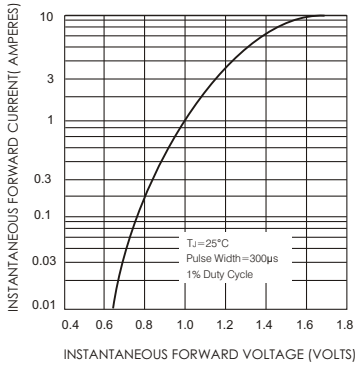

FIG.4-TYPICAL REVERSE CHARACTERISTICS

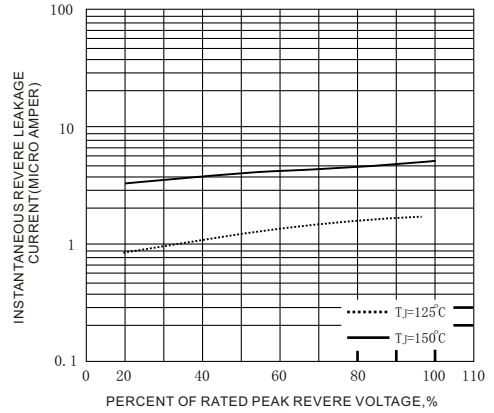

FIG.5-TYPICAL JUNCTION CAPACITANCE

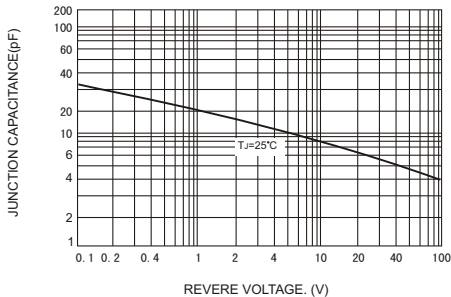

FIG.6-TEST CIRCUIT DIAGRAM AND REVERSE RECOVERY TIME CHARACTERISTIC

